

The High-Security Series

HS336-ADA

Manual Passage Gate • Interior & Exterior Application



Manual and electronic locking access gates and custom filler barriers can be fabricated to match any of our full-height turnstiles. Standard width for passage gates is 36" and customized widths are available – just give us a call.

HS336-ADA
Manual Passage Gate
304 Stainless,
No. 4 Satin finish (shown)

Also available in
hot-dipped galvanized or
powder coat finishes.



8641 South Warhawk Road Conifer, CO 80433
(303) 670-1099 x11 Patrick.McAllister@Turnstiles.us

The High-Security Series

HS336-ADA

Manual Passage Gate • Interior & Exterior Application



Applications:

Ideal for controlling orderly flow of foot traffic in both indoor and outdoor settings (matching gate to our High-Security Full-Height Single and Tandem Turnstiles)

Product Features:

Materials and Finishes available in your choice of:

- Hot dipped galvanized carbon steel
- Polyester enamel on carbon steel (standard color is black/ other colors available upon request)
- Our signature 304 Stainless steel/ No. 4 satin finish

Design & Construction:

- Designed for secure operation with aesthetics in mind
- Featuring fully welded exterior components
- Minimal exposed hardware
- Heavy gauge materials meeting ASTM standards

Measures:

HS336-ADA

Size of opening (pedestrian clearance)
HS336-ADA 36" (914mm)

Frames and Door Jam
2" x 2" (51mm x 51mm) 11 gauge box tubing

Exterior Height
91" (2331mm)

Interior Height
88 1/2" (2248mm)

Interior Tubing Sizes
1 1/2" Diameter 14 gauge (2248mm)
1 3/4" Diameter 14 gauge (44mm)
1 3/4" Diameter 11 gauge (44mm)

Features:

- Swing Gate is equipped with outdoor rated electronic strike lock and automatic door closer
- Keylock - Control direction of travel manually by key (to lock or unlock), or may be used to override electronic controls.

Matching Full-Height Turnstiles Available in Single (HS427-S, HS430-S, HS439-S, HS448-S) and Tandem (HS427-T, HS430-T) Designs.

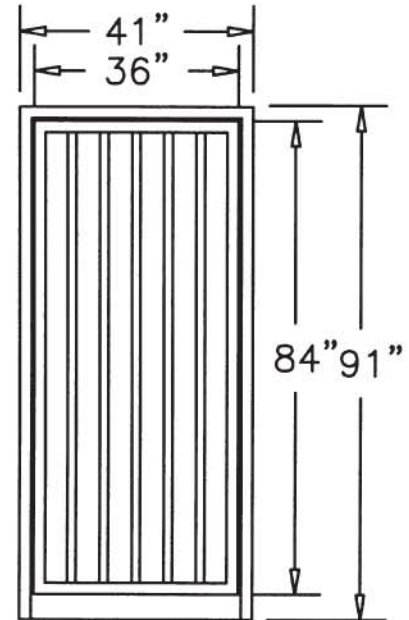

Electrical Specifications:

Command module input 110-240 VAC (2 amp-1 amp) 50-60 Hz; control voltage 24 VDC. All electrical components are UL recognized and CSA certified.

Standards and Codes:

Austenitic stainless steel:
ASTM A240, A249, A276
Hot rolled steel:
AISI C-1020, AISI C-1018
Hot dipped galvanizing:
ASTM A-143, ASTM A-153-80
Stainless steel fasteners:
ASTM A-320
American Welding Society (AWS)
Standard D 1.1

Warranty:

Units are warranted against defects in materials and workmanship for a period of one year from date of delivery. See warranty information for specific details.



8641 South Warhawk Road Conifer, CO 80433
(303) 670-1099 x11 Patrick.McAllister@Turnstiles.us